

The logo for EZ Pack, featuring the text "EZ Pack" in a stylized blue font with a green swoosh underneath.

EZPackTrucks.com

APOLLO A300C Mid-Range Rear Loader



Large Hopper, Low Loading Height, “E-Z Load” Productivity.

Where maximum mobility meets highest productivity in a mid-range hopper. Filled with E-Z Pack durability, reliability and features, the Apollo A300C rear loader offers quick cycle times and three modes of compaction. The A300C packs a punch well above its weight. It's mid-range capacity with a heavy-duty attitude.

Science of Simplicity™

- Simple, straightforward controls make training/operation easy
- Minimal hydraulic and electric lines, junctions and fittings
- Simplified field diagnosis and repair
- No complex computers or PLC to fail

Maximum Payloads and Productivity

- Smart steel engineering reduces overall weight for max payloads
- Customer-tuned Product Optimization

In-the-field Reliability and Durability

- 10/60/20 Testing and Validation™
- Zinc-dichromate-plated tubing/unpainted hydraulic lines

Also available with patent-pending, Integrated CNG Fuel System.

The E-Z Pack Difference

Operator-Owned and -Led

- Entrepreneurial
- Understand the jobsite environment
- Actively listen to customers

Customer-tuned Product Optimization

- Customer collaboration/input
- From-the-field innovation
- Full product/customization

Unwavering Customer Support

- Accessible/knowledgeable support staff
- Wide OEM parts availability
- Quick shipping/technical support

Commitment to Continuous Improvement

- Lean, advanced manufacturing
- Gated QC processes
- 10/60/20 Testing and Validation™

859.234.1100

Apollo A300C Mid-Range Rear Loader



Standard Features

- Manual Controls
- Tailgate Props
- Back-up Alarm
- Body Lifting Eyes
- High Mount Light Package
- ICC Lights and Reflectors Meet DOT Requirements
- Non-Skid Riding Steps at Rear Corners of Tailgate
- Streetside and Curbside Buzzers
- Automatic Latch-Unlatch Tailgate

Optional Equipment

- Air Shift or Hot Shift PTO's
- Street-side Access Door
- Front Mount Pump
- Dual Hopper Flood Lights
- Rear Body Side Liner
- 10,000 lb. (4536 kg) Overhead Winch*
- 14,000 lb. (6350 kg) Reeving Cylinder Winch*
- System Pressure Gauge
- 1-3 Yard (.76 - 2.3 m³) Hydraulic Container Attachment

Operational Features

- COMPACTION CYCLE: Manual hydraulic, automatic split cycle, fully reversible
- CYCLE TIME: 26 seconds, reload @ 9 seconds
- PACKER PANEL: Curved, one-piece construction
- EJECTOR PANEL: Travels in steel guide shoes, floor-level track
- PACKING CYLINDERS: Positioned away from refuse for trouble-free operation
- EJECTOR CYLINDER: Heavy-duty, double-acting, telescopic

* Optional Container Dumping Devices Handle Containers up to 10 Cubic Yards (7.6 m³)

E-Z Pack Refuse Hauling Solutions, LLC, reserves the right under its Product Improvement Program to modify construction and/or design and furnish equipment without reference to illustrations and specifications shown herein. All specifications are subject to change without notice.

Specifications

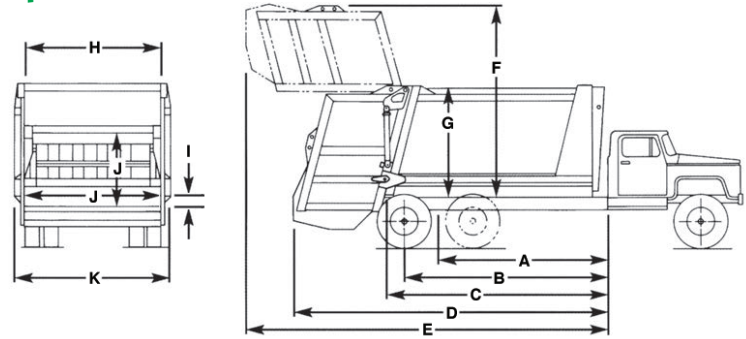

MODEL	A300C-16	A300C-18	A300C-20
CAPACITY	16 yds. ³ (13.8 m ³)	18 yds. ³ (13.8 m ³)	20 yds. ³ (15.3 m ³)
A CAB TO TRUNNION (CT)	NA	NA	126" - 132" (3200 - 3353 mm)
B CAB TO AXLE	105" - 111" (2667 - 2820 mm)	120" - 126" (3048 - 3200 mm)	138" - 144" (3505 - 3658 mm)
C DECK LENGTH CLEAR PLATFORM	140" (3553 mm)	155" (3937 mm)	170" (4318 mm)
D LENGTH (Including Tailgate)	218" (5537 mm)	233" (5664 mm)	238" (6045 mm)
E LENGTH (Tailgate Raised)	247" (6274 mm)	262" (6655 mm)	277" (7036 mm)
F HEIGHT (Tailgate Raised)	156" (3962 mm)		
G HEIGHT (Above Chassis Frame)	90.25" (2292 mm)		
H INSIDE WIDTH (Body)	91" (2311 mm)		
I LOADING HEIGHT (Below Frame)	Up to 5.5" (140 mm) below chassis frame		
J LOADING OPENING	80" (2032 mm) x 58" (1473 mm) high		
K OUTSIDE WIDTH	96" (2438 mm)		
HOPPER CAPACITY	43 yds. ³ (2.3 m ³)		
WEIGHT	9,350 lbs. (4241 kg)	10,050 lbs. (4559 kg)	10,800 lbs. (4899 kg)

Chassis specifications listed are intended as general guidelines only. Each chassis selection should be made on an analysis of the weight distribution for the particular chassis/body combination including optional equipment and anticipated payloads. CNG Models add 14" to length dimensions. Consult factory for CNG systems greater than 60 DGE; Booster pod may require additional length.

CONSTRUCTION AND OPERATIONAL DETAILS

Body Floor	7 ga. (4.55 mm) 50,000 PSI
Body Sides	7 ga. (4.55 mm) 100,000 PSI
Body Roof	10 ga. (3.42 mm) 50,000 PSI
Ejector Panel	7 ga. (4.55 mm) 50,000 PSI
Hopper Floor	1/4" Plate (6.35 mm) 155,000 min. 400 BHN
Hopper Sides (Lower)	1/4" (6.35 mm) 100,000 PSI
Hopper Sides (Upper)	7 ga. (4.55 mm) 50,000 PSI
Packing Panel	7 ga. (4.55 mm) 50,000 PSI

HYDRAULIC SYSTEM

Packing Cylinders (2) w/Induction Hardened Rod & Steel Rod Wipers	4-1/2" (140 mm) (D.A.)
Sweep Cylinders (2) w/Induction Hardened Rod & Steel Rod Wipers	4" (102 mm) (D.A.)
Tailgate Cylinders (2)	3" (76 mm) (D.A.)
Ejector Cylinder (1)	18 Yd. - 5-1/2" (140 mm) 2-Stage (D.A.)
	20 Yd. - 5-1/2" (140 mm) 2-Stage (D.A.)
	25 Yd. - 5-1/2" (140 mm) 3-Stage (D.A.)
Hydraulic Oil Tank	37 Gallons (140 Liters)
Hydraulic Pump	27 G.P.M. @ 1,200 RPM (102 Liter/Min.)
Hydraulic Filters	Suction — 100 Mesh / Return — 3 Micron
System Operating Pressure	2,500 PSI

SPECIAL NOTE:

- 1) PTO Requirements are 39 HP @ 1,200 RPM (Torque Rating 212 ft. lbs.) Minimum
- 2) Chassis MUST be equipped with diesel engine and requires variable speed governor with body builders connection for engine remote throttle, programmed and preset to approximately 1,400 RPM.
- 3) Chassis lighting must be set up and programmed for heavy-duty package and duplicate independent stop and turn signals

859.234.1100 • EZPackTrucks.com

E-Z Pack Refuse Hauling Solutions, LLC • 200 Ladish Road, Cynthiana, KY 41031

A Commercial Specialty Truck Holdings, LLC Company.